



COST LESS LIGHTING

VERSTILE LED EM BACKUP DRIVER

FEATURES

Provides 180-320VDC (or 120-230VAC) constant output to the load during emergency mode operation. For use with switched or unswitched fixtures. Can be used with LED lamp loads of up to 20W.

ELECTRICAL

- Universal 120-277V, 50/60 Hz input
- Charge/Power "ON" LED indicator light and push-to-test switch for mandated code compliance testing
- Long-life, maintenance free, rechargeable NiCad battery
- Output short/overcurrent protection: Electronic limiting, with normal operation resuming upon removal of fault
- 90 Minute minimum emergency operating time over full temperature range
- 24 Hour maximum battery recharge time
- LED illuminated and remote mounted test switch
- Durable painted steel construction in red/orange finish
- Provided with 18" flex conduits on both ends
- Suitable for installation inside or top of the fixture
- UL Recognized for factory installation
- Suitable for damp locations (0°C - 55°C)
- 5-Year Warranty on all electronics and housing.
- Meets UL924, NFPA 101 Life Safety Code, NEC, OSHA, Local and State codes



Push-to-Test Indicator Included

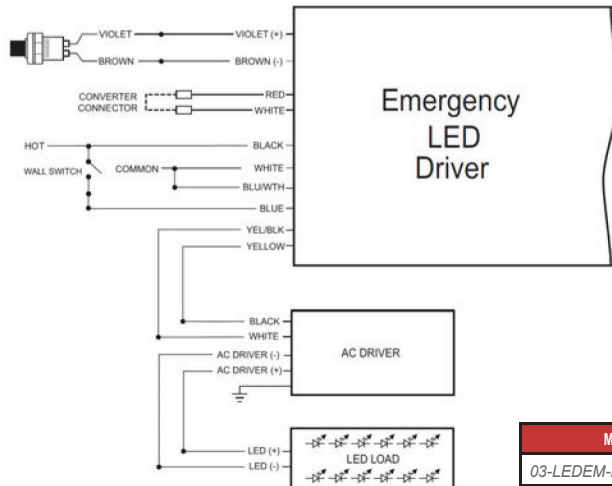
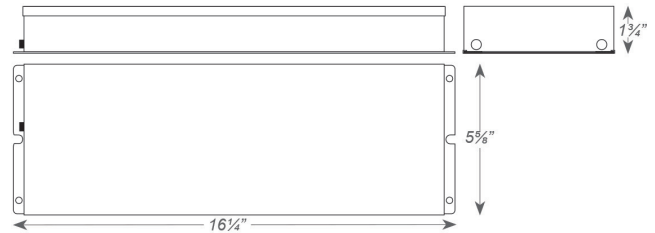

MODEL	INPUT WATTS	OUTPUT WATTS	OUTPUT VOLTAGE	INPUT VOLTAGE
03-LEDEM-BP/DM-20W-E	36	20W	180-320 VDC	120-277VAC (50-60Hz)