

04-GBL-1

ADJUSTABLE RECESSED EMERGENCY DOWN-LIGHT

APPLICATIONS

Adjustable ultra bright 8W bi-pin halogen or 1.5W LED lamp head. Sealed beam PAR36-type gimbal trim with smooth chrome-plated metallized reflector and plastic lens offers optimal light distribution.

FEATURES

- Dual 120/277 voltage.
- Charge rate/power "ON" LED indicator light and push-to-test switch for mandated code compliance testing.
- LVD (low voltage disconnect) prevents battery from deep discharge.
- 6V maintenance-free, rechargeable sealed lead acid battery.
- Internal solid-state transfer switch automatically connects the internal battery to lamp head for minimum 90-minute emergency illumination.
- Fully automatic solid-state, two rate charger initiates battery charging to recharge a discharged battery in 24 hours.

WARRANTY & LISTINGS

- Meets UL924, NFPA 101 Life Safety Code, NEC, OSHA, Local and State Codes.
- UL Listed for dry locations.
- 5-year warranty on all electronics and housing

MOUNTING ARM

- Compatible with drop ceiling mount installations.
Bar hangers included.

HOUSING

- Steel mounting frame and housing.
- 6" recessed housing with mounting bar hangers.
- Impact-resistant thermoplastic adjustable gimbal trim.
- Junction box with 3/4" knockouts for AC input.
- Trim securely attached to housing with spring clips.



DIMENSIONS

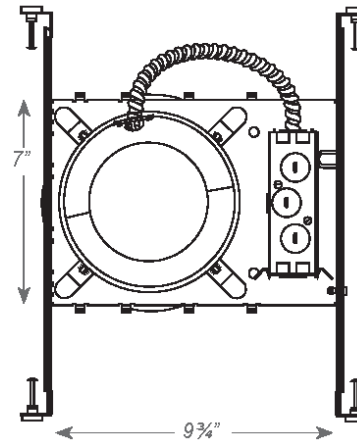
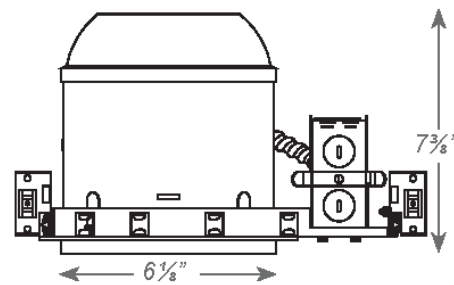

PRODUCT PARAMETER

MODEL	HOUSING COLOR	INPUT WATTS (W)		INPUT AMPS (A)	
		120V	277V	120V	277V
04-GBL	1=White BK= Black	8.0	8.0	0.05	0.05