

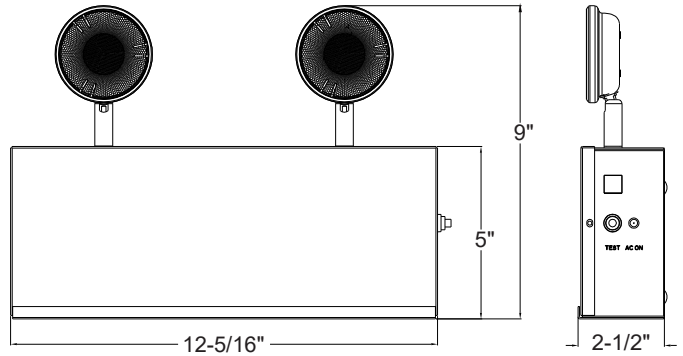

PROJECT	TYPE	CATALOG #



MODEL	HOUSING COLOR
04-CAEM	W = White B = Black

Specifications

Features

- Two, 6V adjustable white LED lamp heads in metal housing and polycarbonate lens provide up to 60-ft center-to-center spacing with a 3-ft path of egress at 7-1/2-ft mounting height.
- 3.3W (3 LEDs x 1.1W) per head with a light output of 335 lumens.

Electrical

- Dual 120/277 voltage.
- Unique bi-color LED indicator light alerts occupant on battery condition (Green-normal, Red-check battery).
- Charge rate/power "ON" LED indicator light and push-to-test switch for mandated code compliance testing.
- LVD (low voltage disconnect) prevents battery from deep discharge.
- 6V sealed lead acid, maintenance-free, rechargeable battery.
- Remote capacity of 5.4W standard.
- Internal solid-state transfer switch automatically connects the internal battery to the LED lamp heads for minimum 90-minute emergency illumination.
- Fully automatic solid-state, two rate charger initiates battery charging to recharge a discharged battery in 24 hours.

Mounting & Housing

- Durable 20-gauge steel construction in white or black finish.
- Universal knockout pattern on back for wall mount.
- Side and top knockouts for conduit feed applications.

Code Compliance

- UL Listed for damp locations (20°C – 50°C).
- Meets UL924, NFPA 101 Life Safety Code, NEC, OSHA, Local and State Codes.
- Meets city of Chicago requirements.

Warranty

- 5-year warranty on all electronics and housing. Battery pro-rated for two years.



Electrical Data

CATALOG NUMBER	INPUT WATTS (W)		INPUT AMPS (A)	
	120V	277V	120V	277V
04-CAEM	8.4	9.4	0.08A	0.04A

Remote Lamp Compatibility

MODEL NUMBER	BATTERY	REMOTE CAPACITY	COMPATIBLE REMOTE HEAD FAMILY				
			RHLED	RH16LED	SRH		SRHLED
					6V	12V	
04-CAEM	6V	5.4W	X	X	X		X