

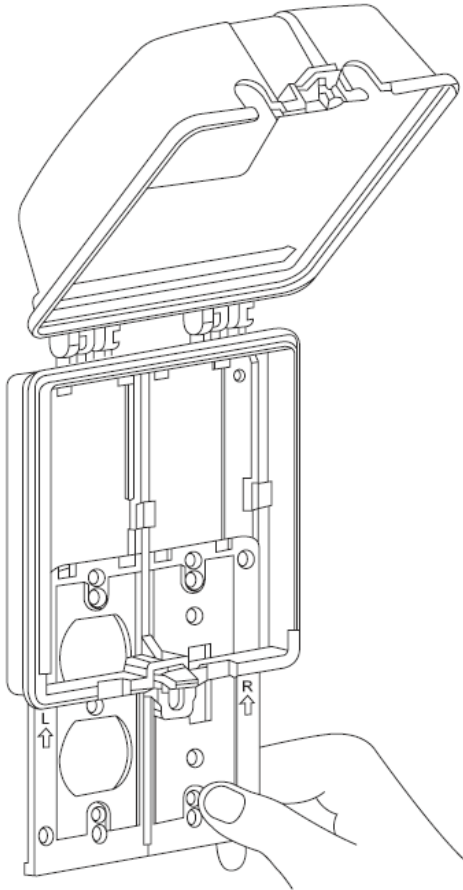

PROJECT	TYPE	CATALOG #



### Features

- Weather-proof
- Quick Fit Installs in Seconds.
- Maximum Versatility
- Impact Resistant
- UV Stabilized
- Non-Conductive
- Multiple faceplate configurations included

### Applications

- Wet locations and Extra-Duty Applications.
- 15 and 20Amps, 120 and 250V receptacles installed outdoors in wet locations shall have an enclosure that is weatherproof whether or not the attachment plug cap is inserted.

MODELS	DESCRIPTION
13-IUC1V	Weather Proof, Vertical, 1 Gang Gfci, Clear Cover
13-IUC2V	Weather Proof, Vertical, 2 Gang Gfci, Clear Cover

1 Gang

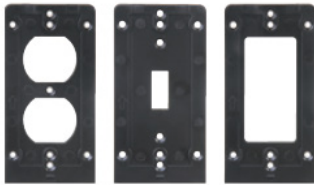

2 Gang



13-IUC1V



13-IUC2V

